

Accepted Manuscript

Selection of the suitable polymer for supercritical fluid assisted preparation of carvedilol solid dispersions

Jelena Djuris, Stoja Milovanovic, Djordje Medarevic, Vladimir Dobricic, Aleksandra Dapčević, Svetlana Ibric

PII: S0378-5173(18)30833-0
DOI: <https://doi.org/10.1016/j.ijpharm.2018.11.015>
Reference: IJP 17908

To appear in: *International Journal of Pharmaceutics*

Received Date: 3 July 2018
Revised Date: 5 November 2018
Accepted Date: 7 November 2018

Please cite this article as: J. Djuris, S. Milovanovic, D. Medarevic, V. Dobricic, A. Dapčević, S. Ibric, Selection of the suitable polymer for supercritical fluid assisted preparation of carvedilol solid dispersions, *International Journal of Pharmaceutics* (2018), doi: <https://doi.org/10.1016/j.ijpharm.2018.11.015>

This is a PDF file of an unedited manuscript that has been accepted for publication. As a service to our customers we are providing this early version of the manuscript. The manuscript will undergo copyediting, typesetting, and review of the resulting proof before it is published in its final form. Please note that during the production process errors may be discovered which could affect the content, and all legal disclaimers that apply to the journal pertain.



Selection of the suitable polymer for supercritical fluid assisted preparation of carvedilol solid dispersions

Jelena Djuris^{1*}, Stoja Milovanovic², Djordje Medarevic¹, Vladimir Dobricic¹, Aleksandra Dapčević², Svetlana Ibric¹

¹University of Belgrade, Faculty of Pharmacy, Vojvode Stepe 450, 11221 Belgrade, Serbia

²University of Belgrade, Faculty of Technology and Metallurgy, Karnegijeva 4, 11120 Belgrade, Serbia

* Corresponding author. Tel.: +381 11 3951363. E-mail address: jelena.djuris@pharmacy.bg.ac.rs

Abstract

Solid dispersions production is one of the substantial approaches for improvement of poor drug solubility. Additionally, supercritical fluid assisted method for preparation of solid dispersions can offer many advantages in comparison to the conventional melting or solvent-evaporation methods. Miscibility analysis provides valuable guidance for selection of the most appropriate polymeric carrier for dispersion of the drug of interest. In addition to the increased drug release rate, solid dispersions should have proper mechanical attributes in order to be successfully formulated in the final solid dosage form such as tablet. Therefore, several pharmaceutical grade polymers have been selected for development of BCS Class II drug carvedilol (CARV) solid dispersions. They were compared based on behavior in supercritical CO₂ and affinity towards CARV calculated from the miscibility analysis. By utilization of the supercritical CO₂ assisted method, solid dispersions of CARV with the selected (co)polymers (polyvinylpyrrolidone(PVP), hydroxypropyl methylcellulose (HPMC), Soluplus[®] and Eudragit[®]) were obtained. Properties of the prepared CARV-polymer dispersions were observed by the polarizing and scanning electron microscopy and analyzed by differential scanning calorimetry and Fourier transform infrared spectroscopy. CARV was additionally characterized by X-ray powder diffraction. Furthermore, *in vitro* dissolution studies and dynamic compaction analysis were performed on the selected samples of solid dispersions. Among the studied polymers, PVP and HPMC have been identified as polymers with the highest affinity towards CARV, based on the calculated δ_p values. This

has been also confirmed with the highest dissolution efficiency of CARV-PVP and CARV-HPMC solid dispersions. Solid state characterization indicated that CARV was dispersed either molecularly, or in the amorphous form, depending on interactions with each polymer. Determination of CARV-PVP and CARV-HPMC mechanical properties revealed that CARV-PVP solid dispersion has superior compactibility and tableability. Therefore, CARV-PVP solid dispersion has been highlighted as the most appropriate for the further development of tablets as the final dosage form. Presented study provides an example for efficient approach for development of poorly soluble drug solid dispersion with satisfactory tableting properties.

Keywords: Carvedilol, supercritical CO₂, solid dispersion, improved dissolution, tableability

1. Introduction

Solid dispersions facilitate delivery of poorly soluble drugs and are considered to be feasible for application by the pharmaceutical industry (Kalepu and Nekkanti, 2015). Considering this, it is understandable that a number of marketed products based on the concept of solid dispersions is in increase nowadays (Huang and Dai, 2014). Depending on the state of the dispersed drug in the carrier, solid dispersions can be amorphous and/or crystalline. Preparation of amorphous dispersions of poorly soluble drugs in polymers are considered to be the most viable approach for improvement of drug poor solubility and oral absorption issues (Baghel et al., 2016). Increase in drug dissolution rate is attributed to enhancement in the wettability and dispersibility (Vo et al., 2013). Drug in the amorphous solid dispersion can be dispersed in very small size (molecular, amorphous particle or small crystals) and exist in the supersaturated state (Vo et al., 2013). It is expected that solid dispersions containing drug in its amorphous form have faster dissolution rates compared to their counterparts with the crystalline drug form. Amorphous dispersions are predominantly developed using polymers, both synthetic and bio polymers (Taylor and Zografi, 1997) such as polyethylene glycol (PEG) (Bley et al., 2010), polymethacrylates (Huang et al., 2006), hydroxypropylmethylcellulose (HPMC) (Kim et al., 2006), polyvinylpyrrolidone (PVP) (Sharma and Jain, 2010) or Soluplus[®] (Kalivoda et al., 2010), which is a co-polymer with surfactant properties. More details on the interactions between the dispersed drug and the selected polymer can be found elsewhere (Huang and Dai, 2014). Selection of the most suitable polymer for dispersion of a poorly soluble drug might present a challenge. Marsac et al. (2006) have introduced the importance of assessment of miscibility/solubility of the drug and candidate polymer(s). Simple and efficient technique for prediction of the miscibility between the two components of amorphous system is comparison of their respective Hansen solubility parameters (Hansen, 2007).

Solid dispersions can be prepared by the two distinct groups of methods: melting and solvent evaporation or by their combination. Hot-melt extrusion is a melting method that can be relatively easily adapted for the application in pharmaceutical industry. Its major drawback, as for the other melting methods, is the fact that both the drug and the polymer need to be thermostable, as well as miscible and compatible at the heating temperature (Vo et al., 2013). Furthermore, the cooling phase could introduce instability, i.e. phase separation. It was also reported that amorphous solid dispersions prepared by the melting methods have poor flowability and compressibility (Vo et al., 2013) which might present challenge in development of solid dosage forms such as tablets. Most of these issues may be resolved by applying some of solvent evaporation based methods (e.g. spray drying). Solvent evaporation based methods usually require the use of an organic solvent common for the drug and polymer such as methanol, ethanol, ethyl acetate, methylene chloride, acetone, or their mixtures with water (Hoshino et al., 2007). The main disadvantage of this method is the impossibility to evaporate the solvent completely, which is important since some of the listed solvents might lead to toxicity issues or instability in the solid dispersion upon storage. Also, from the industrial point of view, these methods are unfavorable vis-a-vis environment requesting the safety measures during the production. Grodowska and Parczewski (2010) have elaborated upon the safety issues regarding the organic solvents commonly used in the pharmaceutical industry. Alternative to organic solvents for solid dispersions production can be found in the use of supercritical fluids (Potter et al., 2015) among which supercritical CO₂ (scCO₂) stands out due to its non-toxicity, inertness, low surface tension, low price and ease of recovery (Taberero et al., 2012). Unique and tunable properties of scCO₂ (density similar to liquids, yet the diffusivity and viscosity similar to gases) (Taberero et al., 2012) allow its versatile application as a solvent, antisolvent, extracting or blowing agent. Some of CO₂-assisted methods that are employed for production of drug-polymer formulations include rapid expansion of supercritical solution (RESS), formation of particles from gas saturated solutions (PGSS), supercritical antisolvent precipitation (SAS), supercritical fluid extraction of emulsions (SFEE) etc. (Taberero et al., 2012; Won et al., 2005; Gong et al., 2008). Solid dispersions of various drugs have been prepared using supercritical CO₂, including: itraconazole (Yin et al., 2015), glibenclamide (Tabbakhian et al., 2014), tacrolimus (Obaidat et al., 2017), nimodipine (Riekens et al., 2015), etc. It was recently reported that scCO₂-assisted process for solid dispersion preparation can be performed in a static regime by exposure of drug and polymer mixture to the scCO₂ without mixing (Potter et al., 2015; Obaidat et al., 2017). This is a single-step process in which scCO₂ promotes mixing of the drug and polymer(s) while at the same time acts as a temporary plasticizer (Potter et al., 2015). After the process, CO₂ diffuses out from the drug-polymer leaving obtained solid dispersion solvent-free (Kazarian and Martirosyan, 2002). Since there are no potentially toxic residues and waste of the solvent, process with scCO₂ is considered to be an environmentally friendly and green technique (Kazarian and Martirosyan, 2002). Carvedilol (CARV) is a BCS (Biopharmaceutics Classification System) class II drug (Shamma and Basha, 2013), with its poor solubility being the limiting factor for dissolution from the dosage form

and subsequent absorption. CARV is a drug with the pH dependent solubility, whereby its solubility decreases with the increase in pH. Liu et al. (2015) have reported that the effective permeability of CARV is the highest in the jejunum. Various (co)polymers have been used to prepare solid dispersions of CARV, including povidone (Sharma and Jain, 2010; Lee et al., 2013), HPMC (Shim et al., 2012; Garhy et al., 2018), Soluplus[®] (Shamma and Basha, 2013; Kaljevic et al., 2017) and Eudragit[®] (Nagy et al., 2012) using variety of methods such as solvent evaporation (Sharma and Jain, 2010), freeze and spray drying (Shamma and Basha, 2013; Shim et al., 2012), electrospinning (Kaljevic et al., 2017) and scCO₂-assisted processing (Nagy et al., 2012). Abuzar et al. (2018) have review the potential of scCO₂ assisted processing for enhancement of solubility and bioavailability of poorly soluble drugs.

The aim of this study was to investigate the potential of selected (co)polymers (povidone, HPMC, Eudragit[®] E-100 and Soluplus[®]) for preparation of CARV solid dispersion assisted by scCO₂ process. Miscibility/solubility of CARV and selected polymers were used to predict and interpret the obtained results of CARV dissolution rate, accompanied by the solid state characterization of the prepared solid dispersions, including dynamic compaction analysis. Presented approach is novel and supports the scCO₂-assisted methods for preparation of poorly soluble drug solid dispersions. Furthermore, there are no previous reports on the analysis of compression and compaction properties of solid dispersions prepared by the scCO₂-assisted method. Concurrent assessment of dissolution and mechanical properties of solid dispersions (including construction of compressibility, compactibility and tableability profiles) has been demonstrated as a convenient tool for selection of the most appropriate polymer for the development of the solid dispersion that increases dissolution of poorly soluble drug in the final solid dosage form.

2. Materials and methods

2.1 Materials

Materials used in the presented study are: carvedilol (CARV, Ph. Eur. 9.0) and following (co)polymers: polyvinylpyrrolidone (PVP, Kollidon[®] 30, BASF, Germany), hydroxypropyl methylcellulose (HPMC, Methocel[®] E5 LV, Dow[®], USA), polyvinyl acetate and polyvinyl caprolactam copolymer (Soluplus[®], BASF, Germany) and poly-(N-dimethylaminoethyl methacrylate-co-methyl methacrylate-co-butyl methacrylate (Eudragit[®] E-100, Evonik, Germany). Commercial carbon dioxide (purity 99%) was supplied by Messer-Tehnogas (Serbia).

2.2 Methods

2.2.1 Determination of miscibility between CARV and selected polymers

Miscibility of CARV and selected polymers was assessed based on the concept of Hansen solubility parameters (Meng et al., 2015), whereby small difference in the solubility parameters δ_t is indicative of favorable miscibility between the drug and the polymer. The total solubility parameter δ_t is a reflection of interactions between dispersion forces (δ_d), polar interactions (δ_p) and hydrogen bonding (δ_h) of the functional groups, as represented in the following equation:

$$\delta_t^2 = \delta_d^2 + \delta_p^2 + \delta_h^2 \text{ (Eq. 1)}$$

According to Greenhalgh et al. (1999) for $\Delta\delta t < 7.0 \text{ MPa}^{1/2}$, miscibility is likely to occur.

2. 2. 2 Preparation of solid dispersions by supercritical CO₂-assisted method

Two grams of each polymer-drug mixture were gently mixed for 2 minutes, using the mortar and the pestle, and placed in mesh covered glass vial. Drug to polymer ratio in all mixtures was 0.3:1. The vial was set in a high pressure vessel (volume of 280 mL) of a high pressure unit presented in Figure 1 (Eurotechnica GmbH, Germany). Uniform heating of the samples was provided by electrical heating jacket located around the vessel. After the desired temperature of 100 °C was reached, pressure was elevated to 30 MPa. System was kept in a static mode without mixing at desired pressure and temperature for 2 hours after which decompression of system was performed with rate of 1.5 MPa/min.

For comparison reasons, pure CARV was exposed to high temperature of 100 °C for 2 h (thermally treated CARV), and also to scCO₂ under the same conditions as polymer-CARV mixtures of 100 °C and 30 MPa for 2 h (CARV treated by scCO₂) in this equipment.

< Figure 1 >

2. 2. 3 Scanning electron microscopy (SEM)

Scanning electron microscope (J.S.M. 840A, JEOL, Tokyo, Japan) was used to visualize the shape and surface of the investigated samples. Samples were placed in the microscope holder and images were taken at a suitable magnification.

2. 2. 4 Polarizing microscopy

Microscopic observations of samples were done under a polarized light microscope Olympus BX 51P (Olympus, Japan). Cross-polarization was used to investigate crystallinity of samples.

2. 2. 5 Differential scanning calorimetry (DSC) studies

Differential scanning calorimetry (Mettler Toledo GmbH Analytical, Giessen, Germany) was used for characterization of the solid state of CARV in the prepared solid dispersions. Test conditions were: temperature range 25-200 °C; heating rate 10 °C/min, and flow of pure nitrogen gas 50 ml/min.

2. 2. 6 Fourier transform infrared (FTIR) spectroscopy

Fourier transform infrared (FTIR) spectra were obtained using a Nicolet iS10 (Thermo Fisher Scientific Inc., Madison, WI, USA) spectrometer which was employed to characterize the potential interactions between the drug and the polymer in the solid state. The FTIR spectra of samples were obtained using an attenuated total reflectance (ATR) accessory in the range of 600 cm⁻¹ to 4000 cm⁻¹, and with a resolution of 2 cm⁻¹.

2. 2. 7 X-ray powder diffraction

The pure drug CARV as well as thermally treated CARV and CARV treated with scCO₂ were examined on an Ital Structure APD 2000 X-ray powder diffractometer using Cu K α radiation ($\lambda =$

1.5418 Å) in a range $5 - 45^\circ 2\theta$ with a step-width of 0.02° and a constant counting time of 1 s per step in order to check the expected drug amorphisation.

2. 2. 8 *In vitro* dissolution studies

In vitro dissolution studies were carried out in 0.1N HCl (900 mL) at $37 \pm 0.5^\circ\text{C}$ using USP dissolution apparatus type II (Erweka DT 600, Hausenstamm, Germany), according to the compendial requirements (USP 40-NF 35, 2017) Solid dispersions, each containing 12.5 mg of CARV (corresponding to its therapeutic dose), were gently placed in the vessels. Reported CARV solubility in the 0.7% HCL (pH 1.45) is $545.1 \pm 5.0 \mu\text{g/mL}$ (Hamed et al., 2016). Since the amount of CARV that can be dissolved in the dissolution medium is 39.24 times greater than the amount of drug in the samples to be dissolved, *sink* conditions have been provided. Paddle rotation was 50 rpm, and aliquots of dissolution medium were withdrawn for the total period of 3 hours (5, 10, 15, 20, 30, 45, 60, 90, 120, 150 and 180 minutes). CARV content in dissolution medium was determined by using UV spectrophotometer (Evolution 300, Thermo Fisher Scientific, Loughborough, USA) at 285 nm. The following dissolution parameters were determined: Q10, which is the amount of Carvedilol (in %) released after 10 minutes of the dissolution test; t_{50} which is the time (in minutes) required for the dissolution of 50% of Carvedilol; %DE30, %DE60 and %DE90, which are percentages of dissolution efficiencies (DE) after 30, 60 and 90 minutes, respectively.

2. 2. 9 Dynamic compaction analysis

Benchtop single-punch Gamlen tablet press (GTP, series D, Gamlen TabletingLtd. Biocity Nottingham, UK) was used for dynamic compaction analysis of the investigated materials. Compacts (50 mg) were compressed under four different loads in the range from 200 to 500 kg (equivalent to 69.43 to 173.57 MPa compaction pressure) using 6 mm flat-faced punches without any embossing, engraving or bevelled edge at compaction speed of 10 mm/min. The supporting software enabled complete visualization of the upper punch position and force in real time. The measured force-displacement curves were used to calculate: (i) work of compression; (ii) tablet behavior in the decompression phase (elastic recovery); (iii) the friction force between lower punch and tablet during detachment phase (detachment stress), and (iv) the friction force between die and tablet in the ejection process (ejection stress). After ejection, the caliper was used for out-of-die compact thickness measurements, while compact hardness and diameter were evaluated using the hardness tester (ErwekaTBH 125D, Erweka, Heusenstamm, Germany). Compact tensile strength σ was calculated using the Eq. 2:

$$\sigma \text{ (MPa)} = \frac{2 \times F}{\pi \times R \times t} \text{ (Eq. 2)}$$

where F is the force applied for compact breaking, R is the compact diameter, and t is the out-of-die compact thickness. According to the calculated values of solid fraction, tensile strength and

compaction pressure, tableability, compressibility and compactibility profiles of the investigated samples were constructed (USP 40-NF 35, 2017).

Powders' compressibility was analyzed according to the Heckel equation:

Eq. 3:

$$\ln\left(\frac{1}{1-D}\right) = K \times \sigma_d + A \quad (\text{Eq. 3})$$

where D is the relative density of materials, σ_d is the applied compression pressure, K is the slope which is correlated to the plasticity of materials and A is an intercept.

3. Results and discussion

3.1 Miscibility of CARV and selected polymers

Values of the total solubility parameter δ_t and parameters reflecting dispersion forces (δ_d), polar (δ_p) and hydrogen bonding (δ_h) interactions of the functional groups for CARV and polymers used in the study are represented in Table 1. Values have been obtained from the listed references for CARV and Soluplus[®] (Kaljevic et al., 2017), scCO₂ (Williams et al., 2004), PVP (Li et al., 2014), Eudragit[®] E 100 (Kitak et al., 2015) and HPMC (Dowwolff Cellulosics, 2018).

< Table 1 >

Differences in the values of total solubility parameters between CARV and selected polymers range from 1.2 (for Eudragit[®] E 100) to 2.9 (for Soluplus[®]). These small differences are in favor of miscibility between the drug and each polymer and subsequent preparation of solid dispersions. This means that, according to the preliminary investigation, all four investigated polymers would be suitable for preparation of CARV solid dispersions.

In order to further investigate the potential for interactions between different functional groups of CARV and polymers, the values for δ_d , δ_h and δ_p for each material were plotted on Figure 2. It is expected that materials with similar values for δ_d , δ_h and δ_p form more stable formulations. It is hence obvious that the affinity towards dispersive and hydrogen bonding is similar amongst CARV and polymers, whereas the potential for polar interactions varies significantly (Figure 2). PVP and HPMC have the greatest δ_p values.

< Figure 2 >

According to the representation in Figure 2, CARV and PVP have the most similar values of δ_d , δ_h and δ_p , indicating that, among the selected polymers, PVP has the greatest affinity to form the stable solid dispersion with CARV.

Another important aspect for the development of supercritical fluid assisted process of solid dispersions preparation is the affinity of both drug and selected polymer towards scCO_2 . In general, principle steps involved in the formulation of a solid dispersion from drug-polymer mixture involve: a) the generation of a liquid (or rubbery) state via melting or dissolution, b) mixing of the components in the liquid state, and c) their subsequent solidification (Potter et al., 2015). It is known that scCO_2 has the ability to plasticize and swell polymers (such as Soluplus[®], Eudragit[®], PVP and HPMC) and penetrate their intermolecular spaces (Potter et al., 2015). Another aspect that has been proposed is that the greatest degree of drug amorphization in solid dispersion can be achieved when the drug has a high affinity for the polymer and at least partial solubility in the scCO_2 (Potter et al., 2015). The drug should be able to dissolve in CO_2 but then partition more favorably into the polymer, resulting in the drug being molecularly dispersed in the polymer, which is favorable for both aqueous drug dissolution and morphological stability (Potter et al., 2015). Therefore, considering good affinity of CARV to selected polymers, relatively small solubility of CARV in scCO_2 (1.1×10^{-5} – 5.0×10^{-3} determined after 3 h static process with shaking at temperatures 35–65 °C and pressures 16–40 MPa) (Shojaeae et al., 2013), and ability of scCO_2 to plasticize amorphous polymers, it can be assumed that selected scCO_2 -assisted process is appropriate for CARV solid dispersion production. This assumption is further tested.

3. 2 Characterization of the prepared solid dispersions

Solid dispersions of CARV with PVP, HPMC, Eudragit[®], and Soluplus[®](co)polymers were obtained by static scCO_2 -assisted process at 30 MPa and 100 °C for 2 h. Depending on the polymer, obtained solid dispersions were in the form of foam (CARV-Eudragit[®] and CARV-Soluplus[®]), flakes (CARV-PVP) or rods (CARV-HPMC).

3. 2. 1 Scanning electron and polarizing light microscopy studies

SEM images of the obtained CARV solid dispersions are presented in Figure 3. Compared to SEM images of pure polymers previously reported (Obaidat et al., 2017; Kumar and Archana, 2015), it can be stated that all polymers went through morphological change upon preparation of solid dispersions. Also, since the clearly visible CARV crystals are lacking within the foam-like morphology of CARV-Eudragit[®] and CARV-Soluplus[®] samples,, it can be concluded that the drug is adsorbed and homogeneously dispersed in polymers at the molecular level (Obaidat et al., 2017; Potluri et al., 2011).

< Figure 3 >

Polarized light microscopy was used to inspect the presence of crystallinity in prepared samples, and the obtained micrographs are represented in Figure 4. Figure 4 demonstrates the lack of crystallinity in

CARV-PVP and CARV-Soluplus[®] solid dispersions upon preparation. These amorphous systems are complex and may represent solid solutions of the drug in the polymer (i.e. molecular dispersions) or dispersions of nano-crystalline drug particles.

< Figure 4 >

It is well known that the dispersed drug often exists in more than one state in solid dispersions i.e. it can be dissolved (forming glassy solid solution) and/or suspended in the carrier but also it can exist in amorphous and crystalline state at the same time (Vo et al., 2013). The presence of CARV in amorphous form in CARV-PVP and CARV-Soluplus[®] solid dispersions was previously reported (Sharma and Jain, 2010; Shamma and Basha, 2013). In the case of solid dispersions prepared using Eudragit[®] and HPMC, some crystallinity is observed for CARV-Eudragit[®] dispersion, whereas CARV-HPMC dispersions are completely crystalline (Figure 4). Shim et al. (2012) prepared CARV-HPMC and CARV-Eudragit[®] dispersions with the spray drying method and reported complete loss of crystallinity in the solid dispersions. Similarly, Nagy et al. (2012) described amorphous CARV-Eudragit[®] solid dispersions prepared by the hot-melt extrusion technology.

In order to further characterize the samples and investigate the potential for solid state interactions of the prepared samples, FTIR, XRD and DSC studies were performed.

3. 2. 2 Fourier transform infrared spectroscopy

FTIR spectra of CARV treated by scCO₂ and prepared solid dispersions are represented in Figure 5. Upon treatment with scCO₂ CARV has retained its distinctive peaks in FTIR spectra, as represented in Figure 5a. There was no change in peaks at 3344 cm⁻¹ corresponding to the N-H stretching vibration of the secondary amine, at 2994 cm⁻¹ and 2923 cm⁻¹ corresponding to C-H aliphatic stretching (Shamma and Basha, 2013). It is known that exposure of the organic compound to the scCO₂ may lead to shifts in the wavenumbers of maximum absorbance, variations of bandwidths and modifications of intensities in the FTIR spectra, due to the antisymmetric vibrations of the carbon dioxide (Morin, 1999). In the case of CARV treated by scCO₂, N-H bending vibration at 1590 cm⁻¹ was moderately shifted (for 2 cm⁻¹) and the intensity of C-O stretching vibration at 1096 cm⁻¹ increased.

Bands at 2955 cm⁻¹ and 1654 cm⁻¹ in CARV-PVP spectra can be attributed to C-H stretch and C=O group, respectively (Obaidat et al., 2017). CARV-Soluplus[®] solid dispersion spectra has peaks characteristic to Soluplus[®] at 3448 cm⁻¹ (O-H stretching), 2927 cm⁻¹ (aromatic C-H stretching), 1735 cm⁻¹, 1635 cm⁻¹ (C-O stretching), and at 1477 cm⁻¹ (C-O-C stretching) (Obaidat et al., 2017). Absence of the CARV peaks at 3342.71 cm⁻¹ and 1588.14 cm⁻¹ in spectra of solid dispersions with PVP and Soluplus[®] is due to intermolecular hydrogen bonding between the N-H group of CARV and the carbonyl group of these polymers. Similarly, it was reported that scCO₂-assisted process resulted

in interaction of ibuprofen, ketoprofen, and tacrolimus with C=O group of PVP (Obaidat et al., 2017; Kazarian and Martirosyan, 2002; Manna et al., 2007). Also, Obaidat et al. (2017) reported interaction between the O–C and O–H of tacrolimus with the O–H or C=O of Soluplus®.

Solid dispersions prepared with CARV and HPMC or Eudragit® (Figure 5b) display the peaks and bands characteristic to polymers and CARV. Bands characteristic to HPMC were observed at 1069 cm^{-1} (C-O-C group) at 1651 cm^{-1} (C=O of the glucose unit), at 2935 cm^{-1} (C-H stretching), and at 3443 cm^{-1} (O–H stretching) (Rana et al. 2017). Characteristic CARV peaks can be seen at 3444 and 1589 cm^{-1} (CARV-HPMC sample) and 3343 and 1589 cm^{-1} (CARV-Eudragit® sample). Lack of intermolecular interaction between CARV and these two polymers is also evident from the crystal forms observed by polarizing microscopy studies (Figure 4). When Gong et al. (2008) prepared indomethacin-HPMC solid dispersion at 17.2 MPa and 130 °C they reported interaction between the carboxylic acid carbonyl group of indomethacin and hydroxyl group of HPMC.

Shim et al. (2012) reported that CARV solid dispersions, prepared with Eudragit® or HPMC by the spray drying method, lack the distinctive CARV peaks, which is indicative of the influence of the method of preparation on the interactions between the drug and polymer.

< Figure 5 >

3. 2. 3 X-ray powder diffractometry

X-ray powder diffractometry (XRD) was used for solid state characterization of pure CARV, CARV thermally treated at 100 °C for 2 h, and CARV treated with scCO₂ at 100 °C and 30 MPa for 2 h to trace any change in the crystalline state of the drug. The XRD diffractograms are shown in Figure 6. Thermally treated CARV demonstrates almost unchanged XRD pattern, compared to the pure drug, since three strongest reflections were found at 5.88, 17.58 and 18.48° of 2 θ for pure CARV and 5.93, 17.60 and 18.51° of 2 θ for thermally treated one showing crystalline nature of these CARV samples (Essa, 2015; Potluri et al. 2011). On the other hand, the absence of clearly visible peaks on pattern of CARV treated by scCO₂ confirmed the indicated amorphisation. Since the most of the strongest reflections of crystalline CARV are situated between 15 and 25° 2 θ , it is expected that the broad “peak” of amorphous CARV is within this region. Therefore, it has been proved that CARV loses its crystalline form upon exposure to the scCO₂.

< Figure 6 >

3. 2. 4 Differential scanning calorimetry

Pure CARV has a distinctive melting peak at 120.5°C (Figure 7a), whereas CARV treated by scCO₂ undergoes one endothermic transition at 48°C and another one at 114.5°C, with the latter one having significantly lower enthalpy in comparison to the pure (crystalline) CARV. The absence of the sharp

melting endotherm, in the case of CARV treated by scCO₂, is indicative of the positive effect of this processing technique on conversion of poorly soluble CARV from crystalline to amorphous state already shown by XRD analysis (Figure 6).

None of the prepared CARV solid dispersions displayed distinct thermal event in the range of CARV melting point (Figure 7b). Solid dispersions showed only the existence of endothermic peaks characteristic to the pure polymers. Namely, broad endothermic peak ranging from 50 to 150 °C in DSC thermogram of CARV-PVP (Figure 7b) corresponds to endothermic peak of pure PVP (Sharma and Jain, 2010; Obaidat et al., 2017). It can be related to the loss of water present in the sample due to the extremely hygroscopic nature of PVP. Broad endothermic peak ranging from 50 to 115 °C in DSC thermogram of CARV-HPMC (Figure 7b) corresponds to the endothermic peak of the pure HPMC and can be also related to the loss of water (Obaidat et al., 2017). Endothermic peaks around 55 °C in DSC thermograms of CARV-Soluplus[®] and CARV-Eudragit[®] dispersions (Figure 7b) can be related to the glass transition temperature of the pure Soluplus[®] and Eudragit[®] (Obaidat et al., 2017). Absence of CARV peaks in solid dispersions was expected and can be attributed to change of CARV form from crystalline to amorphous as well as to the great miscibility of CARV and selected polymers. The obtained results are in agreement with the previously published findings (Sharma and Jain, 2010; Shim et al., 2012). Affinity of CARV towards polymers, in terms of increased miscibility, rises with the increase in temperature, which occurs during the heating cycle of DSC measurement, and results in the absence of evidence of its crystallinity. But, these results should be interpreted with precaution, because upon cooling samples can retain their crystalline form, as represented through polarized microscopy studies (Figure 4).

< Figure 7 >

3. 2. 5 *In vitro* dissolution studies

Dissolution profiles of pure and CARV treated by scCO₂ and prepared solid dispersions are presented in Figure 8. Plotted values represent arithmetic means of triplicates; the error bars represent the standard deviation of the mean. It can be seen that the dissolution rate of CARV has improved upon treatment by scCO₂, approximately two-fold for the three hours of the dissolution study. Furthermore, each of the selected polymers has additionally improved CARV dissolution rate. The fastest CARV release rate was achieved with solid dispersions prepared using PVP or HPMC, with more than 80% of CARV being released after 10 minutes in the case of both samples.

< Figure 8 >

< Table 2 >

Gong et al. (2008) reported that Indomethacin-HPMC solid dispersion prepared by scCO₂-assisted process increased drug dissolution by 100% in 5 h of dissolution test. Manna et al. (2007) reported increased dissolution of ketoprofen when impregnated in PVP using scCO₂ at 19 MPa and 50 °C up to 5 days. They reported Q_{10} to be 67% and t_{50} to be 7 min.

3. 2. 6 Dynamic compaction analysis

Since the highest dissolution efficiency and the fastest CARV release rate has been accomplished by the solid dispersions prepared with PVP or HPMC, these solid dispersions have been selected for further studies, i.e. for determination of their mechanical properties. These two polymers were already been recognized for their suitability to increase the poorly soluble drug release rate. However, none of the previously published studies have compared the mechanical properties of e PVP or HPMC solid dispersions prepared with the supercritical fluid assisted method. Grymonpre et al. (2016) have demonstrated that hot-melt extrusion method, used for the processing of solid dispersions, may impact the tableting behavior of polyvinyl alcohol formulations. Materials were deforming more elastically, which may lead to problems during the decompression and ejection phase of the tableting process. On the other hand, the same authors have demonstrated that the hot-melt extrusion processing of solid dispersions prepared with Soluplus[®], Kollidon[®] VA 64 or Eudragit[®] EPO have had favorable tableting properties (Grymonpre et al., 2017). Negative impact of the hot-melt extrusion processing on the tableting properties of solid dispersions have also been reported by Boersen et al. (2014), Iyer et al. (2013) and Agrawal et al. (2013). Similar findings have been reported for the spray-dried solid dispersions (Iyer et al., 2013; Agrawal et al., 2013). These findings are indicative of the necessity to evaluate different method that will allow preparation of solid dispersion with properties that are of significance for the tableting. Mechanical properties of CARV-PVP and CARV-HPMC samples obtained by scCO₂-assisted method were analyzed in terms of assessment of their compressibility, compactibility and tabletability. Obtained results are presented in Figures 9 and 10 where plotted values are calculated from measurements of triplicates (the error bars represent the standard deviation of the mean). Effect of compression (including elastic work), detachment, and ejection stresses were also analyzed and presented in Figure 11. Figure 9a represents compressibility profiles for CARV-PVP and CARV-HPMC samples. Solid fraction of 0.85 was achieved with compression pressure of 128 MPa (CARV-PVP) and 131 MPa (CARV-HPMC). These compression pressures are in the range of recommended values for the compressible materials (McCormick, 2015) that provide 0.85 solid fractions of typical pharmaceutical compacts (Hancock et al., 2003). The studied materials are of similar compressibility and deform plastically. Slope of the Heckel equation, as represented in Figure

9b, is slightly lower in the case of CARV-PVP sample compared to CARV-HPMC sample, which means that the inverse value, i.e. yield pressure is higher (144.93 MPa for CARV-PVP vs 103.09 MPa for CARV-HPMC samples). Due to the higher plasticity of CARV-PVP solid dispersion, it can be expected that also it will have higher compactibility and tableability.

< Figure 9 >

Tableability and compactibility profiles in Figure 10 confirm this assumption and the superiority of CARV-PVP solid dispersion. Regardless of the applied compression pressure, and the obtained solid fraction, tensile strength of CARV-HPMC samples never exceeded 2 MPa which is recommended for compacts of 6 mm, prepared under the load of 500 kg. Due to inferior compactibility and tableability, CARV-HPMC solid dispersion would present greater challenge for formulation of tablets as the final dosage form, in comparison to CARV-PVP. One of the reasons for different compaction properties of CARV-PVP and CARV-HPMC solid dispersion could be found in difference in the dispersions particles shape (Figure 3c and 3d). CARV-PVP solid dispersion particles have flake-like shape with higher surface area in comparison to the CARV-HPMC particles which have irregular, rod-like shape. Due to the larger available surface, stronger interparticulate bonds can be formed in the case of CARV-PVP solid dispersion. Sebhatu and Alderborn (1999) have demonstrated that higher surface area (due to the smaller size and differences in the particles surface) may lead to the higher tensile strength of tablets. But, the relationship between the surface area and tablets tensile strength is more complex and depends also on the bonding mechanism (Nyström et al., 1993). Greater compactibility of CARV-PVP solid dispersion is also reflected in higher detachment and ejection stresses for all of the applied compression pressures (Figure 11). Since the tablets of higher tensile strength were prepared, it required greater stresses to detach and eject them from the punch-die assembly. It has been recommended that the ejection stresses should be lower than 3 MPa in order to prevent capping or lamination upon completion of the tableting process (Pitt et al., 2015). Values lower than 5 MPa are acceptable only if tablets are not exposed to extensive mechanical stress, such as in film-coating (Pitt et al., 2015). Low values of both detachment and ejection stresses for CARV-HPMC samples are indicative of low tendency towards sticking and lamination during tableting of these formulations. In the case of CARV-PVP solid dispersion, favorable tableting properties were also obtained for the studied range of compression pressures. Somewhat higher ejection and detachment stresses have been noted for the CARV-PVP samples compressed at 400 and 500 kg pressure, 3.79 MPa ejection stress for the sample compressed at 400 kg and 4.44 MPa detachment stress for the sample compressed at 500 kg, respectively. However, these values are still within the recommended range. Since the CARV-PVP solid dispersion demonstrated high compactibility and tableability, tablets of sufficient tensile strength can be made with lower compression pressures. Therefore, CARV-PVP solid dispersions

prepared with scCO₂ assisted method are of satisfactory compressibility, compactibility and tableability; and no tableting issues are to be expected in the case of tableting of this solid dispersion.

< Figure 10 >

< Figure 11 >

4. Conclusion

The obtained results suggest that the nature of the interactions between the drug and polymer predominantly affect the potential for improvement in the dissolution rate. As represented in the case of poorly soluble drug CARV, it was concluded that PVP and HPMC, as polymers with δ_p values similar to δ_p value of CARV, have great potential to improve CARV dissolution rate in the polar medium.

It has been demonstrated that the analysis of miscibility parameters provides reliable tool for selection of candidate polymers for development of solid dispersions with improved dissolution properties, in comparison to the pure poorly soluble drug CARV.

It was shown that the treatment of CARV with scCO₂ provides amorphisation and increase of CARV release rate. Furthermore, scCO₂ assisted method was successfully used for preparation of CARV solid dispersions with PVP, HPMC, Soluplus[®] and Eudragit[®] that increased drug dissolution rate. This finding reveals the possibilities for development of single step and environment-friendly methods for production of solid dispersions. In the case of CARV-PVP solid dispersions, superior dissolution properties over the solid dispersions prepared by the solvent-evaporation method have been demonstrated. Information of CARV-polymer properties after scCO₂-assisted process, as well as its effect on CARV dissolution, are important since they provide further stimulus for application of the ecological method of processing in the pharmaceutical industry.

Dynamic compaction analysis has been recognized as a convenient tool for early selection of the formulations with the appropriate properties for the tableting. It has been demonstrated that CARV-PVP and CARV-HPMC solid dispersions have similar compressibility, but, due to the superior compactibility and tableability, CARV-PVP solid dispersions has been selected as the most appropriate for the further development of tablets as the final dosage form. These are additional beneficial findings in the favor of scCO₂ method for the preparation of solid dispersions, because it has been proved that this technology enables production of the poorly soluble drug solid dispersions with the satisfactory dissolution and tableting properties. This substantially facilitates further development of the formulation and the processing method for the final dosage form.

Acknowledgments

Financial support of this work from the Ministry of Education, Science and Technological Development of the Republic of Serbia (Projects TR 34007, III 45017 and III 45007) is gratefully acknowledged.

5. References

Abuzar, S.M., Hyun, S.M., Kim, J.H., Park, H.J., Kim, M.S., Park, J.S. and Hwang, S.J., 2018. Enhancing the solubility and bioavailability of poorly water-soluble drugs using supercritical antisolvent (SAS) process. *Int. J. Pharm.*, 538(1-2), 1–13. Doi: 10.1016/j.ijpharm.2017.12.041

Agrawal, A. M., Dudhedia, M. S., Patel, A. D., Raikes, M. S., 2013. Characterization and performance assessment of solid dispersions prepared by hot melt extrusion and spray drying process. *Int. J. Pharm.*, 457(1), 71–81. Doi: 10.1016/j.ijpharm.2013.08.081

Baghel, S., Cathcart, H., O'Reilly, N. J., 2016. Polymeric Amorphous Solid Dispersions: A Review of Amorphization, Crystallization, Stabilization, Solid-State Characterization, and Aqueous Solubilization of Biopharmaceutical Classification System Class II Drugs. *J. Pharm. Sci.*, 105(9), 2527–2544. Doi: 10.1016/j.xphs.2015.10.008

Bley, H., Fussnegger, B., Bodmeier, R., 2010. Characterization and stability of solid dispersions based on PEG/polymer blends. *Int. J. Pharm.*, 390, 165–173. Doi: 10.1016/j.ijpharm.2010.01.039

Boersen, N., Lee, T. W., Shen, X., Hui, H. W., 2014. A preliminary assessment of the impact of hot-melt extrusion on the physico-mechanical properties of a tablet. *Drug. Dev. Ind. Pharm.*, 40(10), 1386–1394. Doi: 10.3109/03639045.2013.828216

DowwolffCellulosics. Solubility parameters, available from: <https://dowac.custhelp.com/ci/fattach/get/19861/0/filename/Solubility+Parameters.pdf>, last accessed April 1st 2018.

Essa, E.A., 2015. Enhancement of Carvedilol Dissolution; Surface Solid Dispersion Versus Solid Dispersion, *Asian J Pharm.*, 9 (4) 283–289 <https://www.asiapharmaceutics.info/index.php/ajp/article/view/469>

Garhy, D.M., Ismail, S., Ibrahim, H.K., Ghorab, M.M., 2018. Buccoadhesive gel of carvedilol nanoparticles for enhanced dissolution and bioavailability. *J. Drug Deliv. Sci. Technol.*, 47, 151–158. Doi: 10.1016/j.jddst.2018.07.009

Gong, K., Rehman, I. U., Darr, J. A., 2008. Characterization and drug release investigation of amorphous drug–hydroxypropyl methylcellulose composites made via supercritical carbon dioxide assisted impregnation. *J. Pharmaceut. Biomed.*, 48, 1112–1119. Doi: 10.1016/j.jpba.2008.08.031

Greenhalgh, D. J., Williams, A. C., Timmins, P., York, P., 1999. Solubility parameters as predictors of miscibility in solid dispersions. *J. Pharm. Sci.*, 88(11), 1182–190. Doi: 10.1021/js9900856

Grodowska, K., Parczewski, A., 2010. Organic solvents in the pharmaceutical industry. *Acta Pol. Pharm.*, 67(1), 3–12.

Grymonpré, W., De Jaeghere, W., Peeters, E., Adriaensens, P., Remon, J. P., Vervaet, C., 2016. The impact of hot-melt extrusion on the tableting behaviour of polyvinyl alcohol. *Int. J. Pharm.*, 498(1-2), 254–262. Doi: 10.1016/j.ijpharm.2015.12.020

Grymonpré, W., Verstraete, G., Van Bockstal, P. J., Van Renterghem, J., Rombouts, P., De Beer, T., Remon, J. P., Vervaet, C., 2017. In-line monitoring of compaction properties on a rotary tablet press during tablet manufacturing of hot-melt extruded amorphous solid dispersions. *Int. J. Pharm.*, 517(1-2), 348–358. Doi: 10.1016/j.ijpharm.2016.12.033

Hamed, R., Awadallah, A., Sunoqrot, S., Tarawneh, O., Nazzal, S., AlBaraghthi, T., Al Sayyad, J., Abbas, A., 2016. pH-dependent solubility and dissolution behavior of carvedilol—case example of a weakly basic BCS class II drug. *AAPS PharmSciTech.*, 17(2), 418–426. Doi: 10.1208/s12249-015-0365-2

Hancock, B. C., Colvin, J. T., Mullarney, P. M., Zinchuk, A.V., 2003. The relative densities of pharmaceutical powders, blends, dry granulations, and immediate-release tablets. *Pharm. Technol.*, 27, 64–80.

Hansen, C. M., 2007. *Hansen solubility parameters: a user's handbook*. Second Edition. CRC Press. Taylor & Francis Group, Boca Raton, Florida, USA.

Hoshino, T., Kusaki, F., Fukui, I., 2007. Solid Dispersion Preparation. European Patent EP 1847260 A3.

Huang, J., Wigent, R.J., Bentzley, C.M., Schwartz, J.B., 2006. Nifedipine solid dispersion in microparticles of ammonio methacrylate copolymer and ethylcellulose binary blend for controlled drug delivery: effect of drug loading on release kinetics. *Int. J. Pharm.*, 319, 44–54. Doi: 10.1016/j.ijpharm.2006.03.035

Huang, Y., Dai, W.G., 2014. Fundamental aspects of solid dispersion technology for poorly soluble drugs. *Acta Pharmaceut. Sin. B.* 4(1), 18–25. Doi: 10.1016/j.apsb.2013.11.001

Iyer, R., Hegde, S., Zhang, Y. E., Dinunzio, J., Singhal, D., Malick, A., Amidon, G., 2013. The impact of hot melt extrusion and spray drying on mechanical properties and tableting indices of materials used in pharmaceutical development. *J. Pharm. Sci.*, 102(10), 3604–3613. Doi: 10.1002/jps.23661

Kalepu, S., Nekkanti, V., 2015. Insoluble drug delivery strategies: review of recent advances and business prospects. *Acta Pharmaceut. Sin. B.* 5(5), 442–453. Doi: 10.1016/j.apsb.2015.07.003

- Kalivoda, A., Fischbach, M., Kleinebudde, P., 2012. Application of mixtures of polymeric carriers for dissolution enhancement of oxeglitazar using hot-melt extrusion. *Int. J. Pharm.*, 439, 145–156. Doi: 10.1016/j.ijpharm.2012.10.013
- Kaljevic, O., Djuris, J., Calija, B., Lavric, Z., Kristl, J., Ibric, S., 2017. Application of miscibility analysis and determination of Soluplus solubility map for development of carvedilol-loaded nanofibers. *Int. J. Pharm.*, 533(2), 445–454. Doi: 10.1016/j.ijpharm.2017.05.017
- Kazarian, S. G., Martirosyan G. G., 2002. Spectroscopy of polymer/drug formulations processed with supercritical fluids: in situ ATR-IR and Raman study of impregnation of ibuprofen into PVP. *Int. J. Pharm.*, 232, 81–90. Doi: 10.1016/S0378-5173(01)00905-X
- Kim, E.J., Chun, M.K., Jang, J.S., Lee, I.H., Lee, K.R., Choi, H.K., 2006. Preparation of a solid dispersion of felodipine using a solvent wetting method. *Eur. J. Pharm. Biopharm.* 64(2), 200–205. Doi: 10.1016/j.ejpb.2006.04.001
- Kitak, T., Dumičić, A., Planinšek, O., Šibanc, R., Srčić, S., 2015. Determination of Solubility Parameters of Ibuprofen and Ibuprofen Lysinate. *Molecules.*, 20, 21549–21568. Doi: 10.3390/molecules201219777
- Kumar, B. P., Archana, G., 2015. Formulation and evaluation of nizatidine solid dispersions. *World. J. Pharm. Pharm. Sci.*, 4, 810–817.
- Lee, S. N., Poudel, B.K., Tran, T. H., Marasini, N., Pradhan, R., Lee, Y. I., Lee, D. W., Woo, J. S., Choi, H. G., Yong, C. S., Kim, J. O., 2013. A novel surface-attached carvedilol solid dispersion with enhanced solubility and dissolution. *Arch. Pharm. Res.* 36(1), 79–85. Doi: 10.1007/s12272-013-0008-7
- Li, L., Jiang, Z., Xu, J., Fang, T., 2014. Predicting Poly(vinyl pyrrolidone)'s Solubility Parameter and Systematic Investigation of the Parameters of Electrospinning with Response Surface Methodology. *J. Appl. Pol. Sci.*, 40304, 1–9. Doi: 10.1002/app.40304
- Liu, D., Pan, H., He, F., Wang, X., Li, J., Yang, X., Pan, W., 2015. Effect of particle size on oral absorption of carvedilol nanosuspensions: in vitro and in vivo evaluation. *Int.J. Nanomed.*, 10, 6425–6434. Doi: 10.2147/IJN.S87143
- Manna, L., Banchemo, M., Davide, S., Ferri, A., Ronchetti, S., Sicardi, S., 2007. Impregnation of PVP microparticles with ketoprofen in the presence of supercritical CO₂. *J. Supercrit. Fluid.*, 42, 378–384. Doi: 10.1016/j.supflu.2006.12.002
- Marsac, P.J., Shamblin, S.L., Taylor, L.S., 2006. Theoretical and practical approaches for prediction of drug-polymer miscibility and solubility. *Pharm. Res.*, 23, 2417–2426. Doi: 10.1007/s11095-006-9063-9
- McCormick, D., 2015. Evolutions in Direct Compression. *Pharm. Technol.*, April, 52–62. Doi: 10.1016/j.ejps.2015.05.018

Nagy, Z. K., Sauceau, M., Nyúl, K., Rodier, E., Vajna, B., Marosi, G., Fages, J., 2012. Use of supercritical CO₂-aided and conventional melt extrusion for enhancing the dissolution rate of an active pharmaceutical ingredient. *Polym. Adv. Technol.*, 23, 909–918. Doi: 10.1002/pat.1991

Nyström, C., Alderborn, G., Duberg, M., Karehill, P. G., 1993. Bonding surface area and bonding mechanism—two important factors for the understanding of powder comparability. *Drug. Dev. Ind. Pharm.*, 19(17-18), 2143–2196. Doi: 10.3109/03639049309047189

Obaidat, R. M., Tashtoush, B. M., Awad, A. A., Al Bustami, R. T., 2017. Using Supercritical Fluid Technology (SFT) in Preparation of Tacrolimus Solid Dispersions. *AAPS PharmSciTech.*, 18(2), 481–493. Doi: 10.1208/s12249-016-0492-4

Pitt, K. G., Webber, R. J., Hill, K. A., Dey, D., Gamlen, M. J., 2015. Compression prediction accuracy from small scale compaction studies to production presses. *Powder. Technol.*, 270, 490–493.

Potluri, R. H. K., Bandari, S., Jukanti, R., Veerareddy, P. R., 2011. Solubility enhancement and physicochemical characterization of Carvedilol solid dispersion with Gelucire 50/13. *Arch. Pharm. Res.*, 34(1), 51–57. Doi: 10.1007/s12272-011-0106-3

Potter, C., Tian, Y., Walker, G., McCoy, C., Hornsby, P., Donnelly, C., Jones, D.S., Andrews, G.P., 2015. Novel Supercritical Carbon Dioxide Impregnation Technique for the Production of Amorphous Solid Drug Dispersions: A Comparison to Hot Melt Extrusion. *Mol. Pharmaceutics.*, 12(5), 1377–1390. Doi: 10.1021/mp500644h

Riekes, M.K., Caon, T., da Silva Jr, J., Sordi, R., Kuminek, G., Bernardi, L.S., Rambo, C.R., de Campos, C.E.M., Fernandes, D. and Stulzer, H.K., 2015. Enhanced hypotensive effect of nimodipine solid dispersions produced by supercritical CO₂ drying. *Powder Technol.*, 278, 204–210. Doi: 10.1016/j.powtec.2015.03.029

Sebhatu, T., Alderborn, G., 1999. Relationships between the effective interparticulate contact area and the tensile strength of tablets of amorphous and crystalline lactose of varying particle size. *Eur. J. Pharm. Sci.*, 8(4), 235–242. Doi: 10.1016/S0928-0987(99)00025-1

Shamma, R. N., Basha, M., 2013. Soluplus®: A novel polymeric solubilizer for optimization of Carvedilol solid dispersions: Formulation design and effect of method of preparation. *Powder. Tech.* 237, 406–414. Doi: 10.1016/j.powtec.2012.12.038

Sharma, A., Jain, C. P., 2010. Preparation and characterization of solid dispersions of carvedilol with PVP K30. *Res. Pharm. Sci.*, 5(1), 49–56.

Shim, J. B., Kim, M. J., Kim, S. J., Kang, S. J., Lee, J. H., Kim, H. S., Lee, D., Khang, G., 2012. Dissolution properties of control released solid dispersion of carvedilol with HPMC and Eudragit RS. *J. Pharm. Inv.*, 42(5), 285–291.

Shojaee, S. A., Rajaeib, H., ZeinolabediniHezaveb, A., Lashkarbolookib, M., Esmaeilzadeh, F., 2013. Experimental investigation and modeling of the solubility of carvedilol in supercritical carbon dioxide. *J. Supercrit. F.*, 81, 42–47. Doi: 10.1016/j.supflu.2013.04.013

Tabbakhian, M., Hasanzadeh, F., Tavakoli, N. and Jamshidian, Z., 2014. Dissolution enhancement of glibenclamide by solid dispersion: solvent evaporation versus a supercritical fluid-based solvent-antisolvent technique. *Res. Pharm. Sci*, 9(5), 337–350.

Tabernerero, A., Martín del Valle, E. M., Galán, M. A., 2012. Supercritical fluids for pharmaceutical particle engineering: Methods, basic fundamentals and modeling. *Chem. Eng. Process.*, 60, 9–25. Doi: 10.1016/j.cep.2012.06.004

Taylor, L. S., Zografí, G., 1997. Spectroscopic characterization of interactions between PVP and indomethacin in amorphous molecular dispersions. *Pharm. Res.*, 14, 1691–1698. Doi: 10.1023/A:1012167410376

USP 40-NF 35. 2017. Chapter <1062> Tablet Compression Characterization. The United States Pharmacopeia and National Formulary USP 40-NF 35. Rockville: United States Pharmacopeial Convention.

Vo, C. L. N., Park, C., Lee, B. J., 2013. Current trends and future perspectives of solid dispersions containing poorly water-soluble drugs. *Eur. J. Pharm. Biopharm.*, 85(3), 799–813. Doi: 10.1016/j.ejpb.2013.09.007

Williams, L. L., Rubin, J. B., Edwards, H. W., 2004. Calculation of Hansen Solubility Parameter Values for a Range of Pressure and Temperature Conditions, Including the Supercritical Fluid Region. *Ind. Eng. Chem. Res.*, 43(16), 4967–4972. Doi: 10.1021/ie0497543

Won, D. H., Kim, M. S., Lee, S., Park, J.S., Hwang, S.J., 2005. Improved physicochemical characteristics of felodipine solid dispersion particles by supercritical anti-solvent precipitation process. *Int. J. Pharm.*, 301, 199–208. Doi: 10.1016/j.ijpharm.2005.05.017

Yin, X., Daintree, L.S., Ding, S., Ledger, D.M., Wang, B., Zhao, W., Qi, J. and Wu, W., 2015. Itraconazole solid dispersion prepared by a supercritical fluid technique: preparation, in vitro characterization, and bioavailability in beagle dogs. *Drug Des. Devel. Ther.*, 9, 2801–2810. Doi: 10.2147/DDDT.S81253

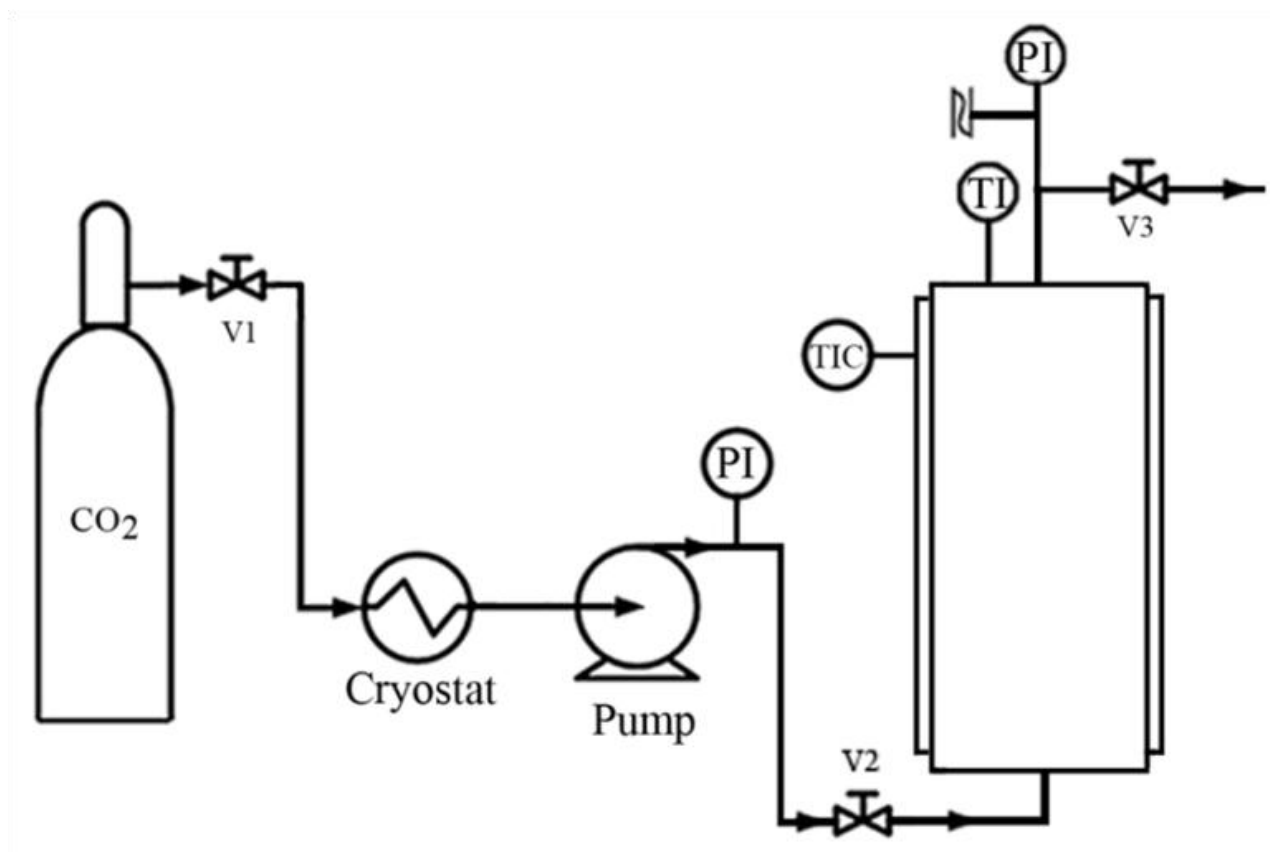

Figure 1. Schematic presentation of the high pressure unit

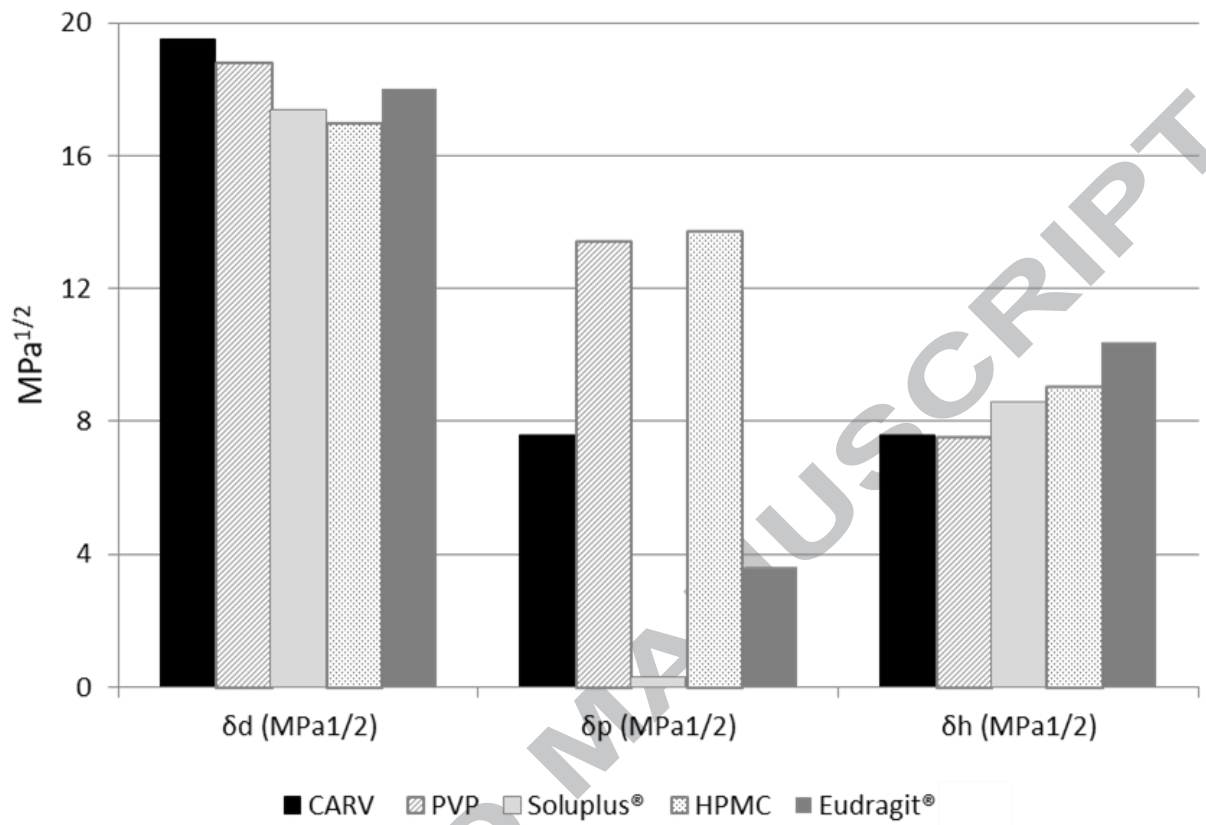

Figure 2. Representation of δ_d , δ_h and δ_p for each material

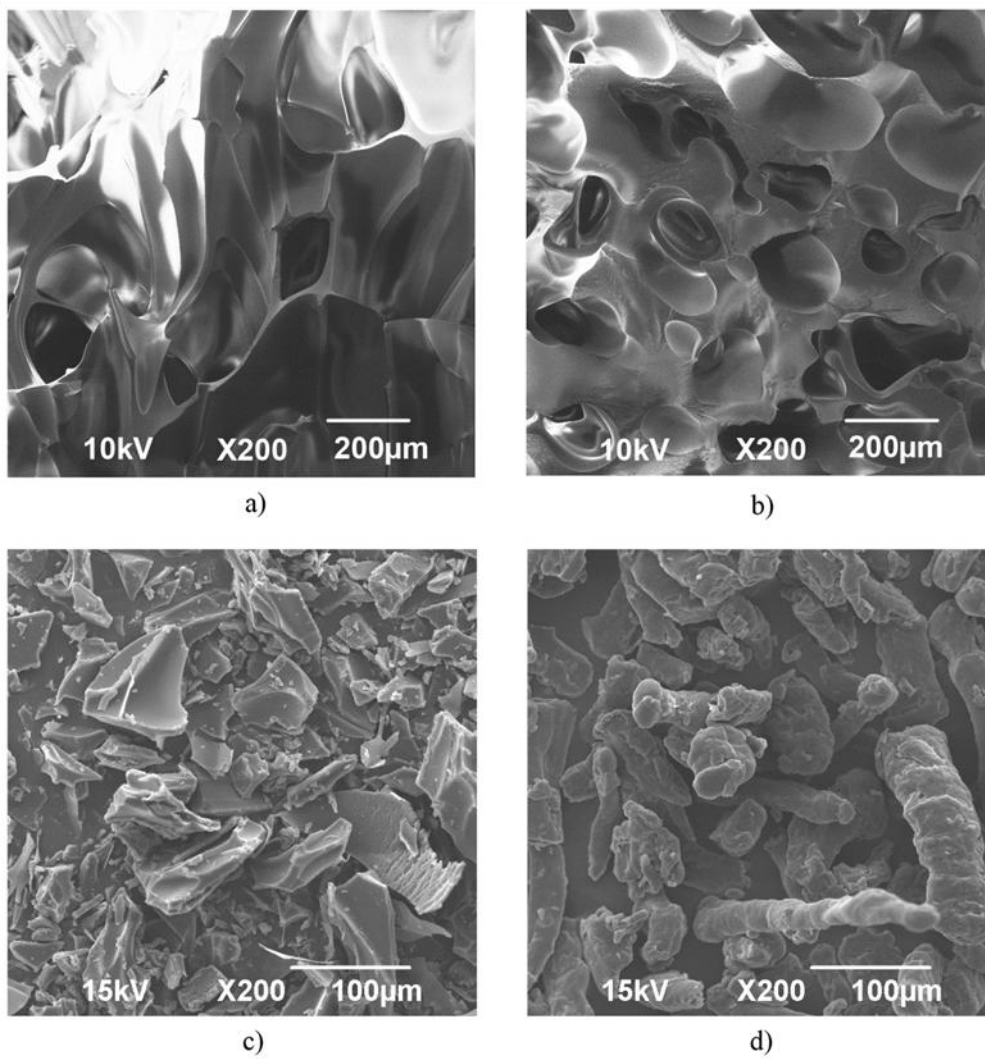

Figure 3. SEM images of CARV solid dispersion with: a) Soluplus®, b) Eudragit®, c) PVP and d) HPMC

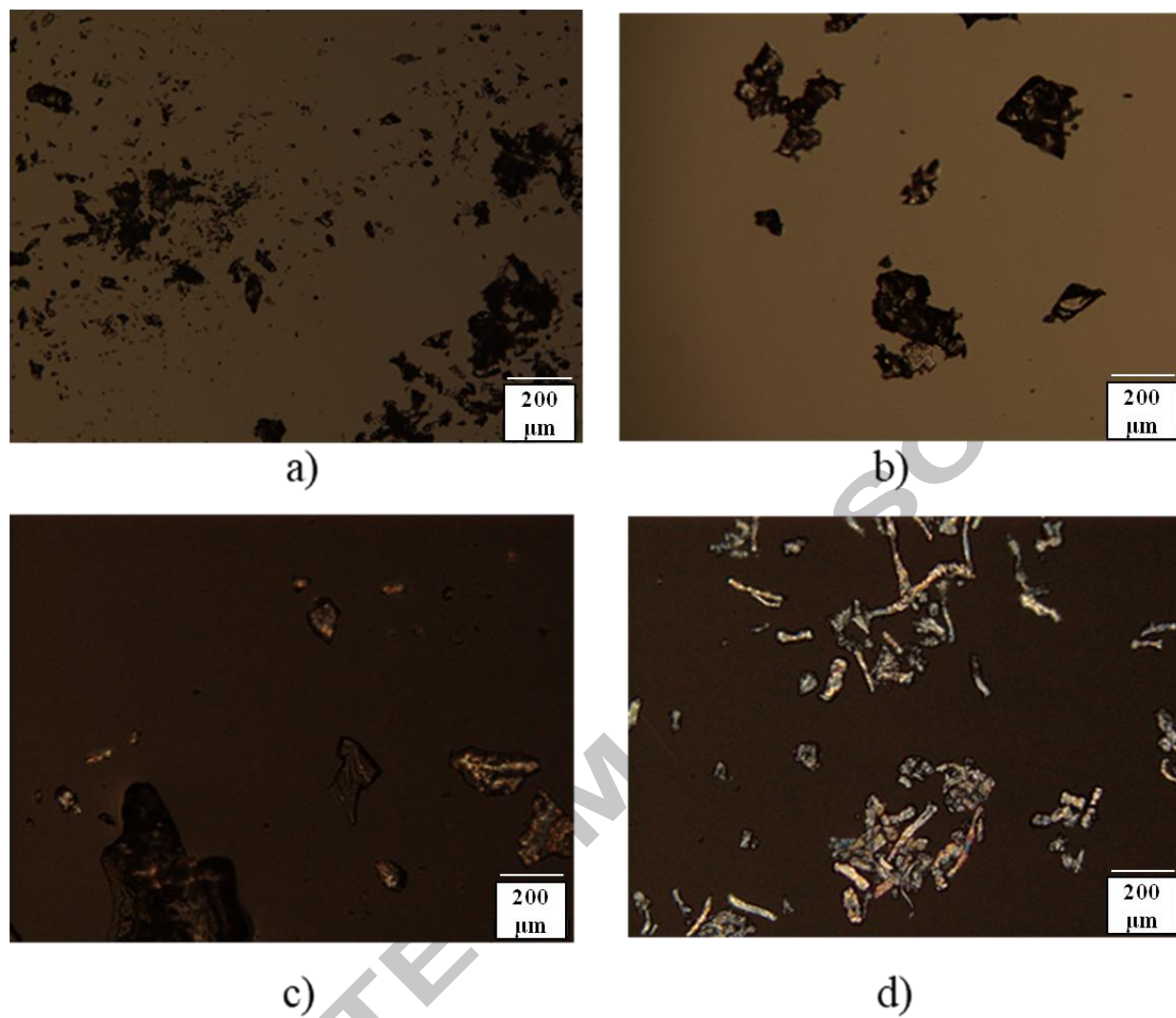

Figure 4. Polarized light microscopies of solid dispersions of CARV and a) PVP (no crystallinity), b) Soluplus® (no crystallinity), c) Eudragit® (some crystallinity observed) and d) HPMC (crystals observed). Magnification used was 100 x (scale bar = 200 μm)

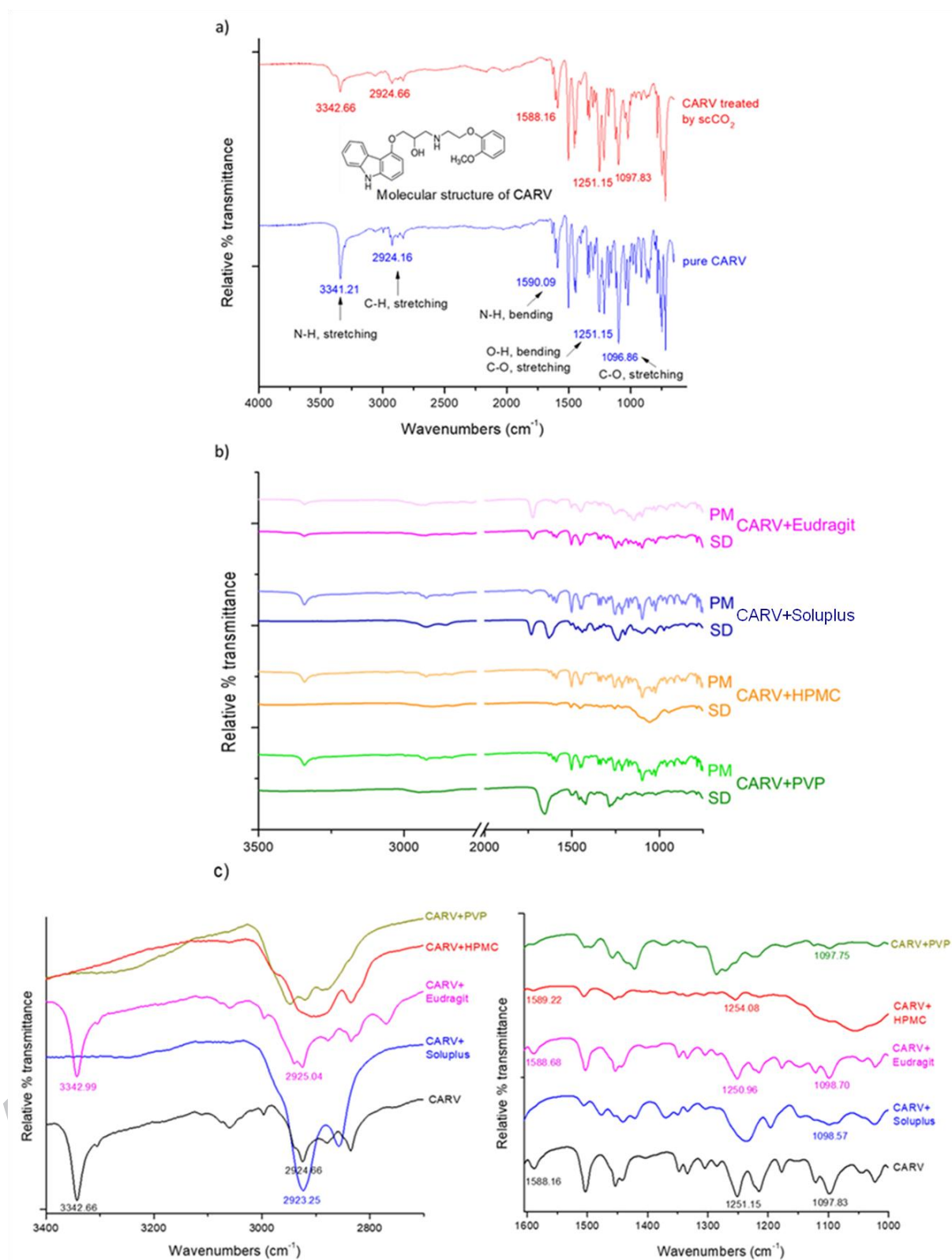

Figure 5. FTIR spectra of (a) pure CARV and CARV treated by $scCO_2$, (b) prepared physical mixtures (PM) and solid dispersions (SD) and (c) prepared solid dispersions and CARV treated by $scCO_2$

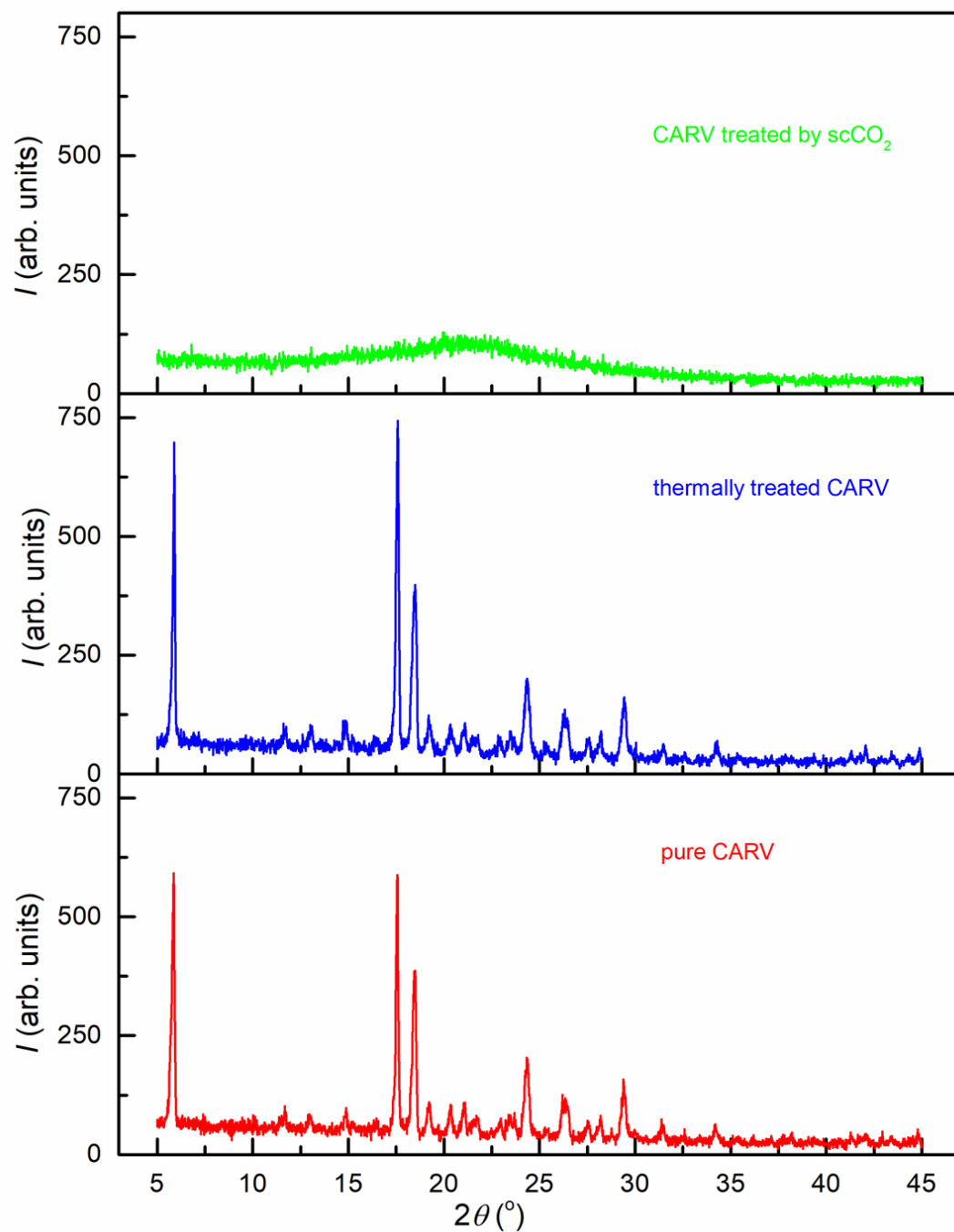

Figure 6. X-Ray diffractograms of pure, thermally treated and CARV treated by scCO_2

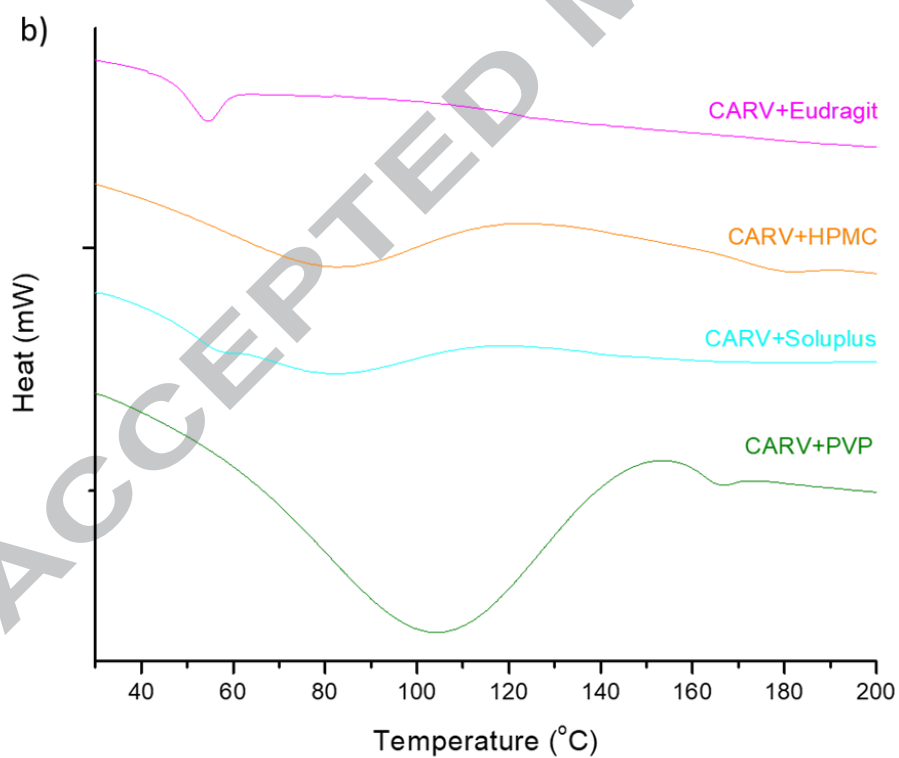
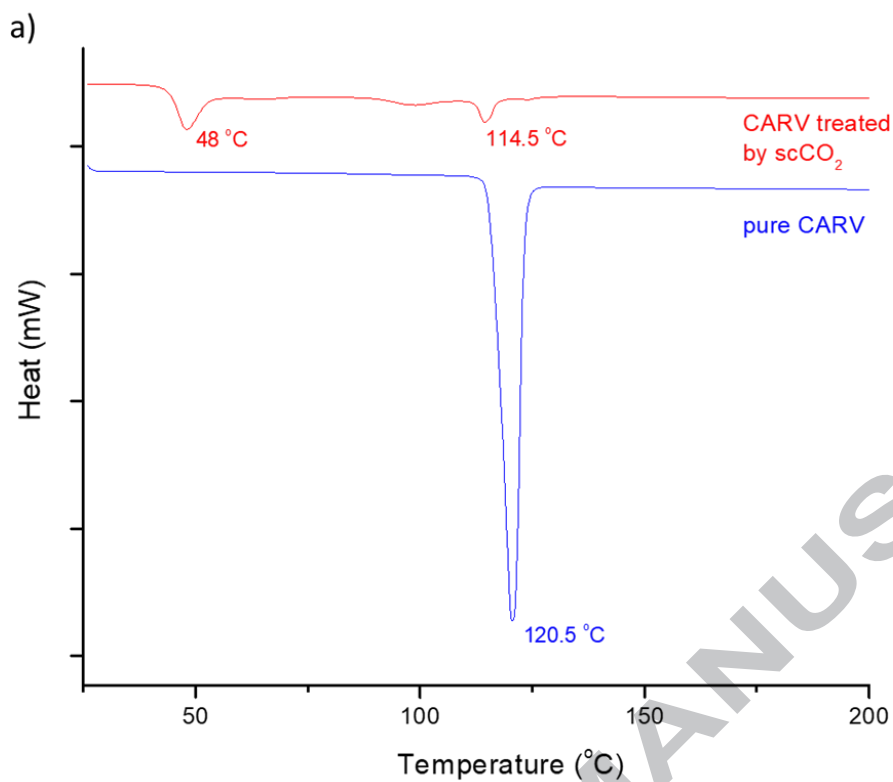

Figure 7. DSC thermograms of (a) pure CARV and CARV treated by $scCO_2$, (b) prepared solid dispersions

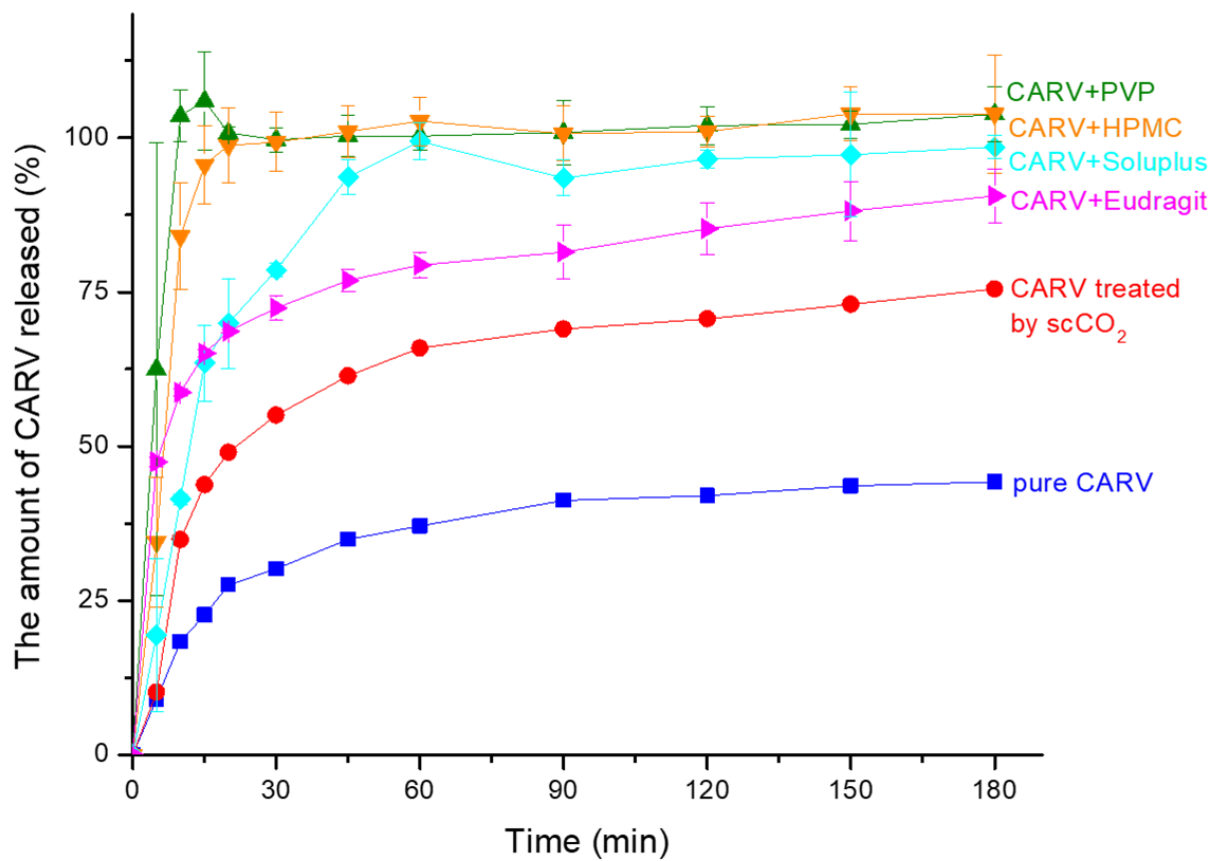

Figure 8. Dissolution profiles of pure and CARV treated by scCO₂ and prepared solid dispersions

ACCEPTED

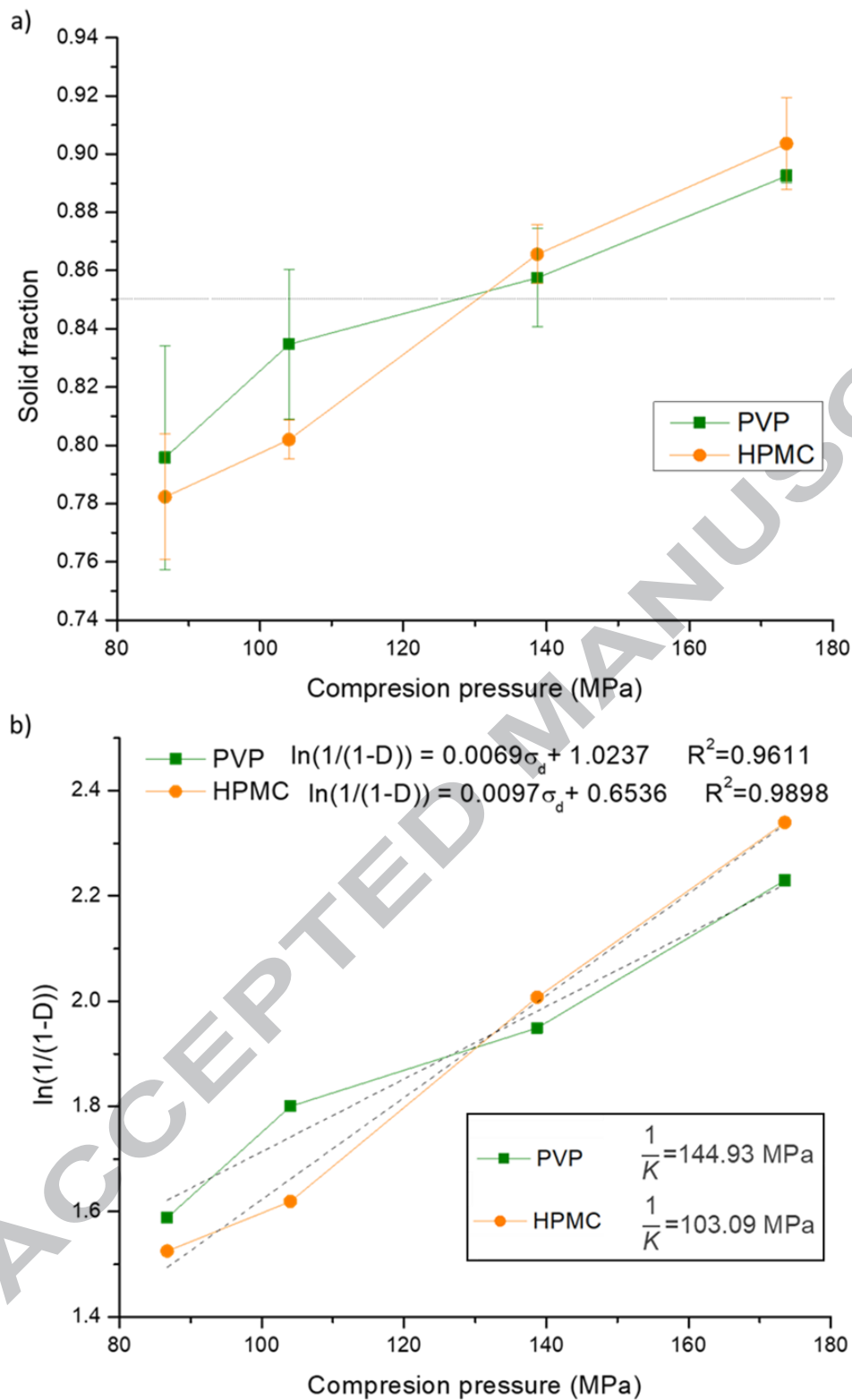

Figure 9. Effect of compression pressure on CARV-PVP and CARV-HPMC solid dispersions: (a) Compressibility profiles and (b) Heckel plots

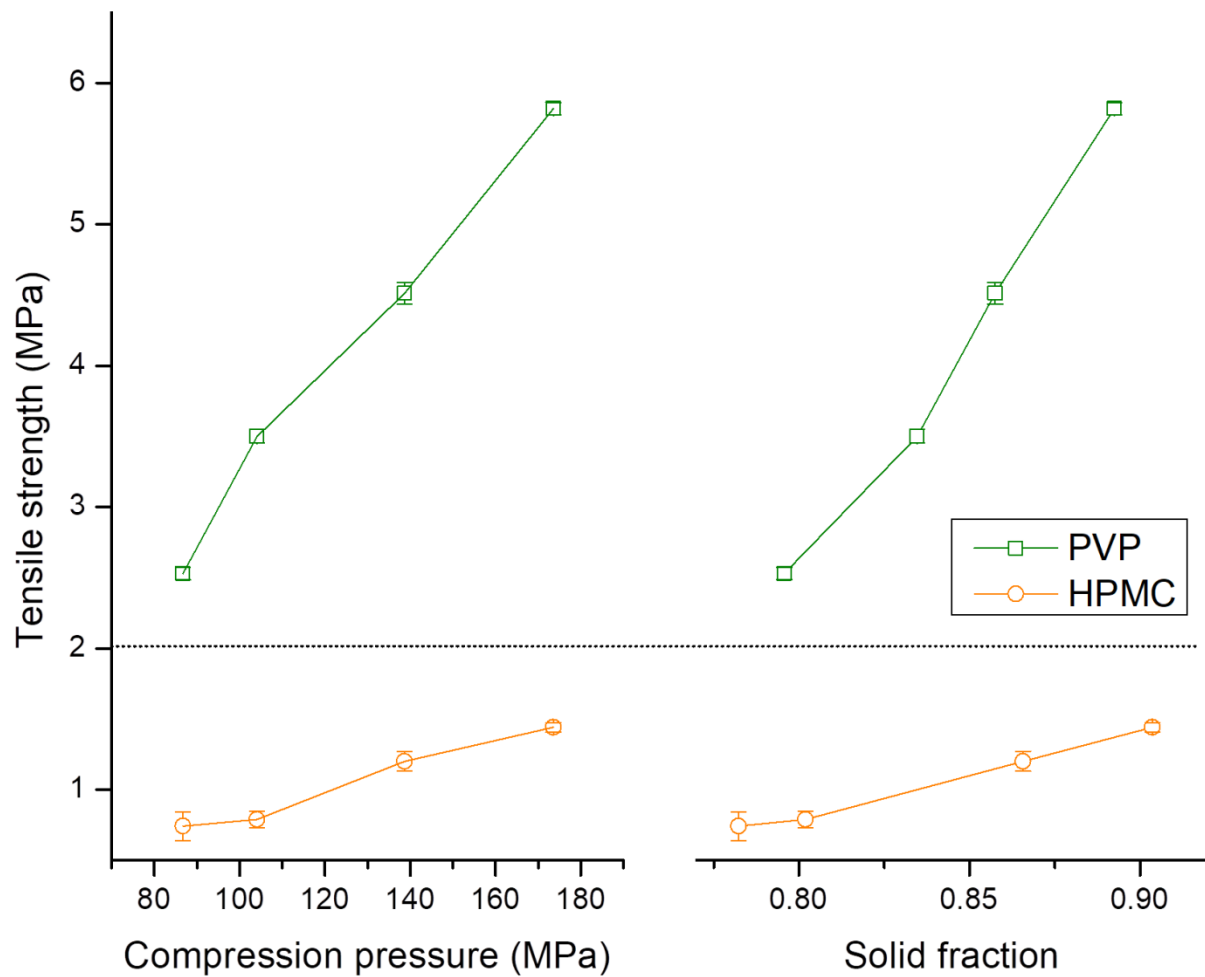

Figure 10. Tableability (compression pressure vs tensile strength) and compactibility profiles (solid fraction vs tensile strength) of CARV-PVP and CARV-HPMC solid dispersions

ACCEPTED

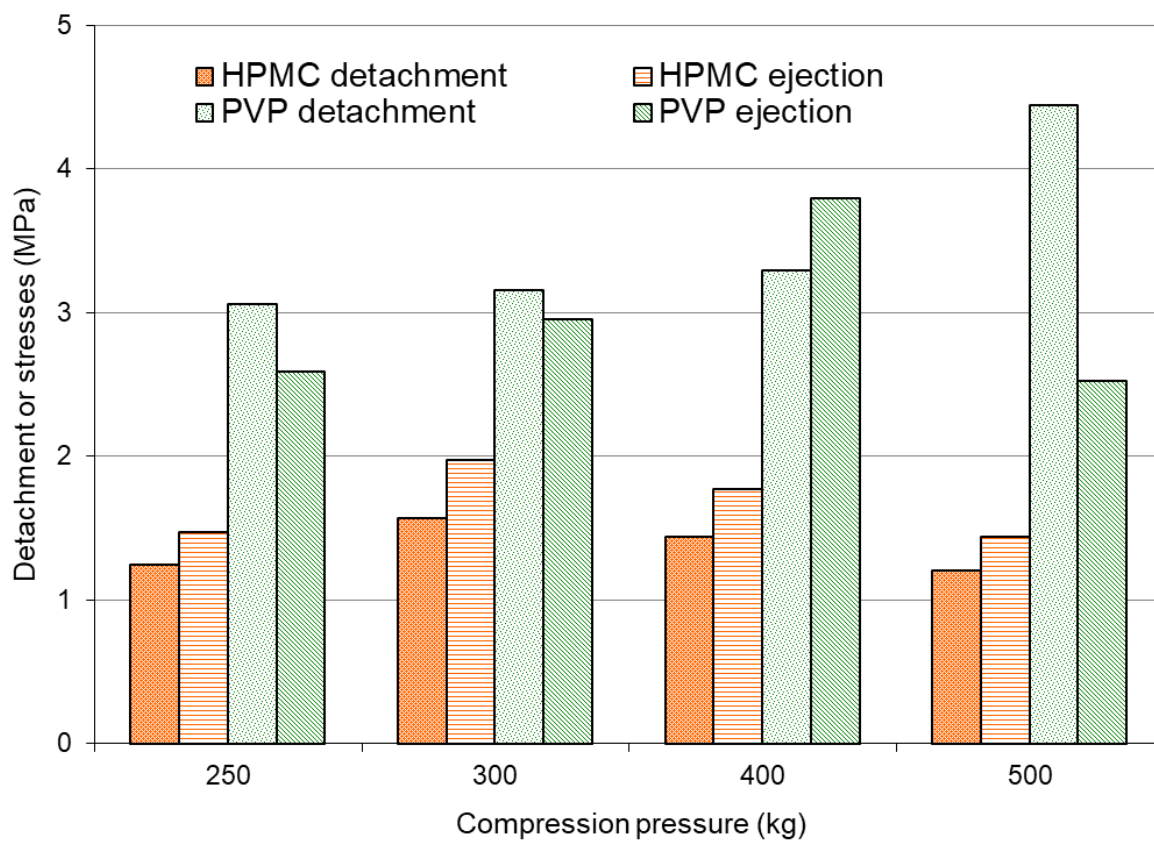

Figure 11. Comparison of detachment and ejection stress measured during the compaction of CARV-PVP and CARV-HPMC solid dispersions

Table 1. Solubility parameters of materials used in the study

Compound	$\delta_d(\text{MPa}^{1/2})$	$\delta_p(\text{MPa}^{1/2})$	$\delta_h(\text{MPa}^{1/2})$	$\delta_t(\text{MPa}^{1/2})$	$\Delta\delta_t(\text{MPa}^{1/2})$
CARV	19.5	7.6	7.6	22.3	-
PVP	18.8	13.4	7.5	24.3	2
Soluplus [®]	17.4	0.3	8.6	19.4	2.9
HPMC	16.95	13.7	9.04	23.59	1.29
Eudragit [®] E 100	18.01	3.64	10.38	21.1	1.2
scCO ₂	15.6	5.2	5.8	17.4	4.9

Table 2. Dissolution parameters of pure and treated Carvedilol and prepared solid dispersions

Sample	Q_{10} (%)	t_{50} (min)	%DE ₃₀	%DE ₆₀	%DE ₉₀
Pure CARV	18.32 ± 9.98	> 180	20.19	27.25	31.23
CARV treated by scCO ₂	34.84 ± 8.93	21.86	36.87	48.38	55.08
CARV-PVP	103.54 ± 4.27	3.62	85.93	93.17	95.72
CARV-HPMC	84.02 ± 8.62	6.37	75.87	88.63	93.12
CARV-Soluplus	41.39 ± 1.83	11.83	51.37	71.57	79.29
CARV-Eudragit	58.70 ± 0.59	6.04	56.80	67.02	71.51

Declaration of interests

The authors declare that they have no known competing financial interests or personal relationships that could have appeared to influence the work reported in this paper.

The authors declare the following financial interests/personal relationships which may be considered as potential competing interests:

Graphical abstract

